

REV.	ECN	BY	CHKD	REVISION
0	RLSE	DFT 5/4/99	JLB 5/4/99	RELEASED FOR PRODUCTION
1	1544	JRS 10/8/99	AEP 10/8/99	.750+.000/- .014 WAS .750; (.150) WAS .150;REVISED NOTES;MATERIAL;HEAT TREAT; PART NAME

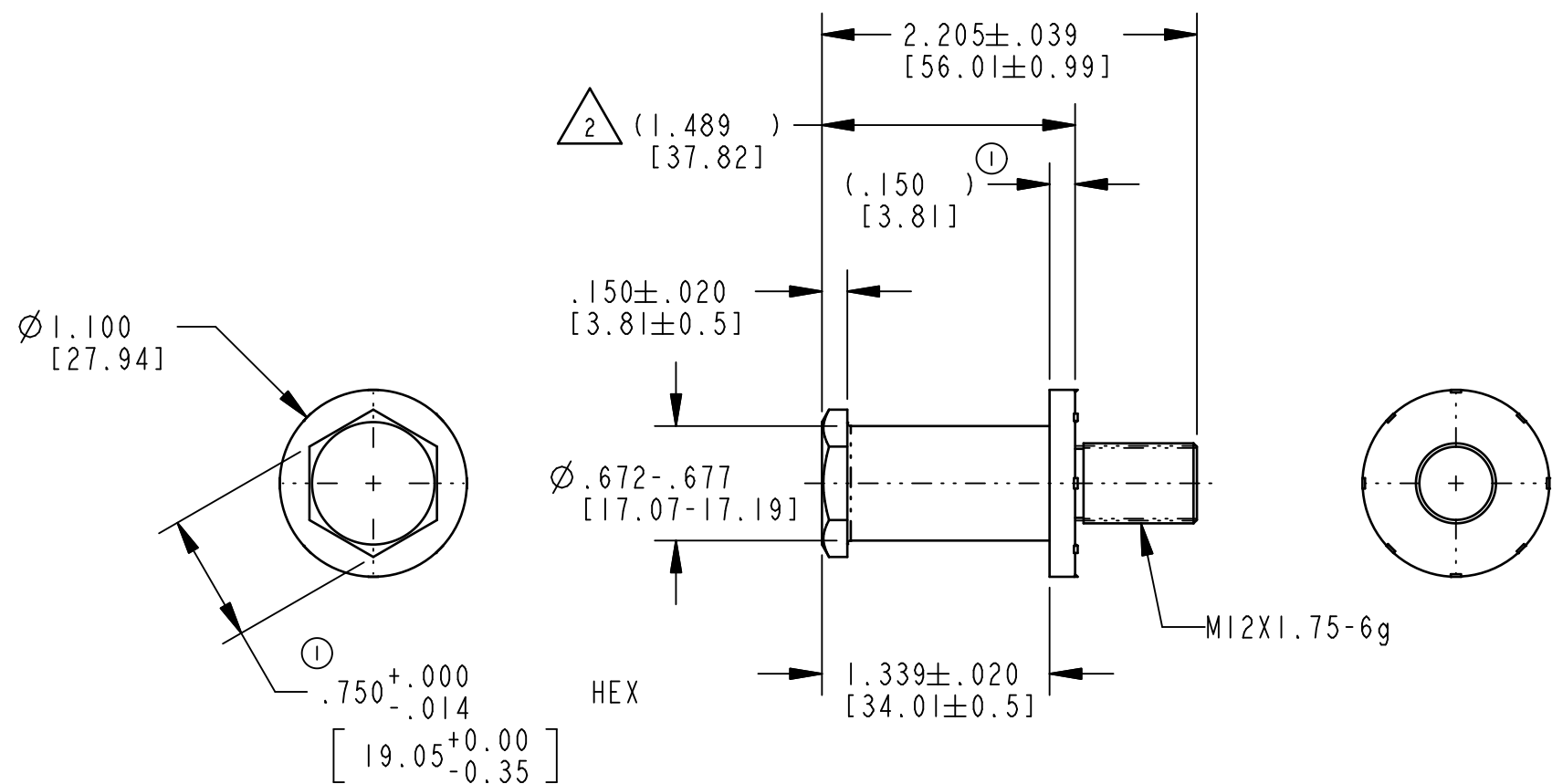

- ① NOTES:
- ① WASHER ORIENTATION IMPORTANT.
 - ② WASHER SHOWN IN INSTALLED POSITION. DIMENSIONS IN [] ARE IN MILLIMETERS FOR REFERENCE ONLY.
 - ③ FINISH IS FOR REFERENCE ONLY.

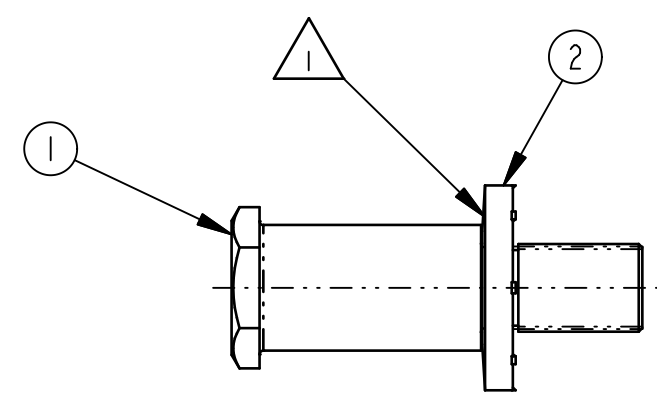

2	16911-01	WSHR, BVL, .500X1.100X.150	1
1	16910-01	BLT, STKR, M12X1.75X2.205, 3/4	1

SPEC	DESCRIPTION	ITEM	PART NO.	DESCRIPTION	QTY.
------	-------------	------	----------	-------------	------

DRAWN BY	DFT	5/4/99	MATL	MATERIAL PER ES-141	
CHECKED BY	JLB	5/4/99	①	HEAT TREAT PER ES-141	
DESIGN ENG.	JLB	5/5/99	①	FINISH PLATE, ZINC/COAT, CHROMATE, YELLOW PER ES-104A	
MFG. ENG.				PROJECT	99044
QUALITY ENG.				CUSTOMER	
TOLERANCES UNLESS OTHERWISE SPECIFIED ANSI Y14.5M-1982 DIMENSIONS ANGLES X.X = ±.1 X° = ±3° X.XX = ±.03 X.X° = ±1.0° X.XXX = ±.010 X.XX° = ±.50°			CUSTOMER PART NO.		
INCH [METRIC]			SIZE	PART WT.	SURFACE AREA
FORM 163-210 REV. 1.0 10/15/93			B		
			PROD CODE	070-0200	
			REPORT ERRORS TO ENGINEERING DEPT.	DO NOT SCALE DRAWING	



THIS DRAWING AND THE INFORMATION CONTAINED HEREIN IS THE PROPERTY OF TRI/MARK CORP. AND SHALL NOT BE USED FOR ANY PURPOSE WITHOUT OUR WRITTEN CONSENT

PART NAME ①		
ASSY, BLT/WSHR, 1.492 SHLDR, M12X1.75		
SCALE	REV.	PART NO.
FULL	1	16912-01