

PART NO.	FINISH
I2168-35	BEZEL, BLACK ABS HANDLE, PLATE, COPPER-NICKEL-CHROME
I2168-37	BEZEL, BLACK ABS HANDLE, PAINT, BLACK, LOW GLOSS

REVISION	ECO	BY	CHECKED	DESCRIPTION

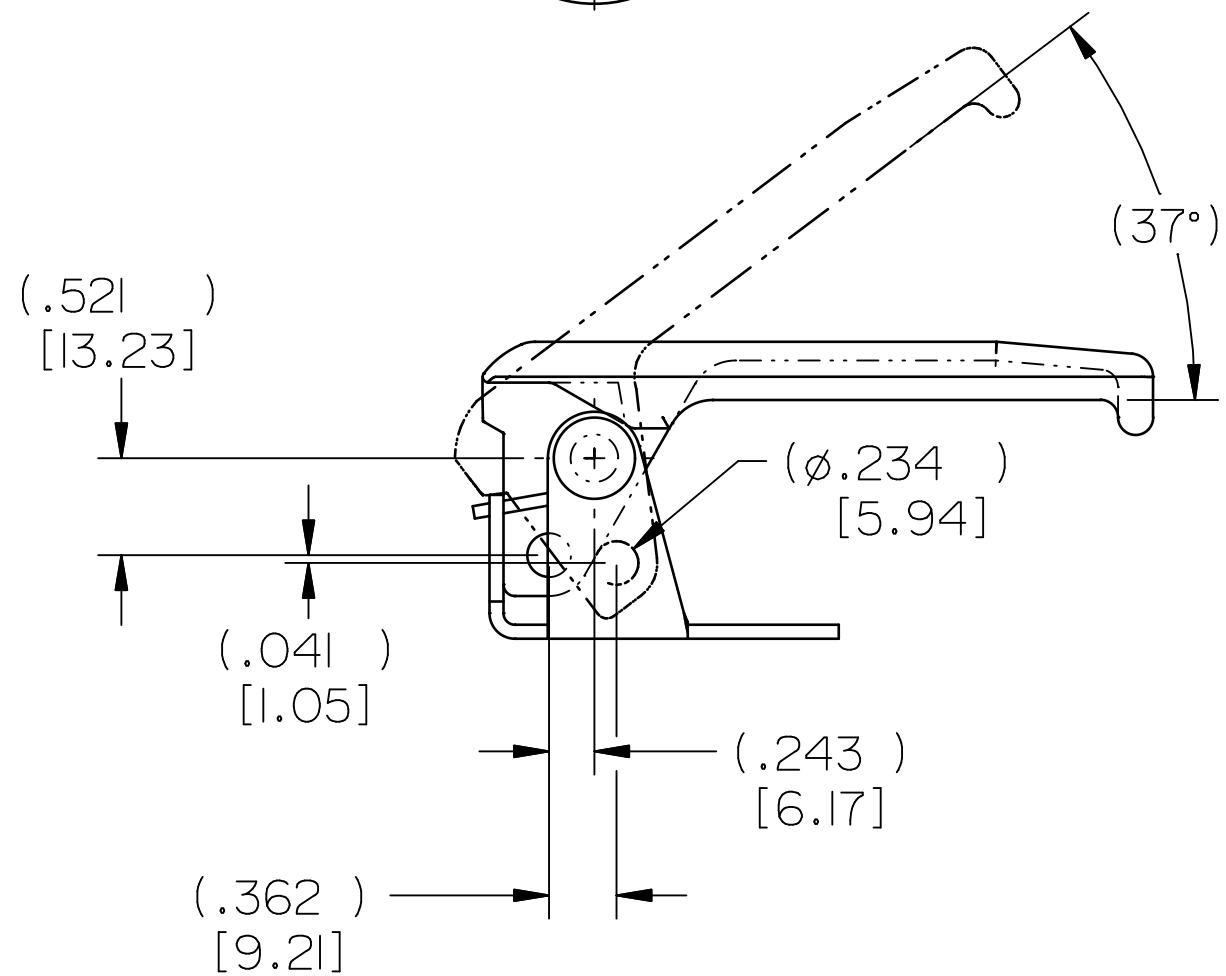

BEZEL NOT SHOWN

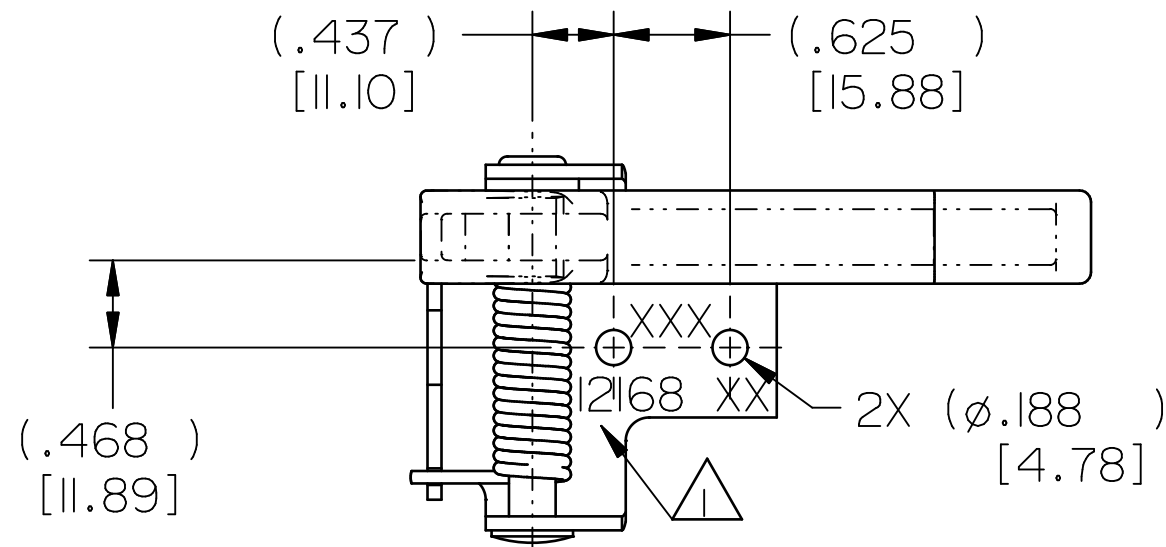
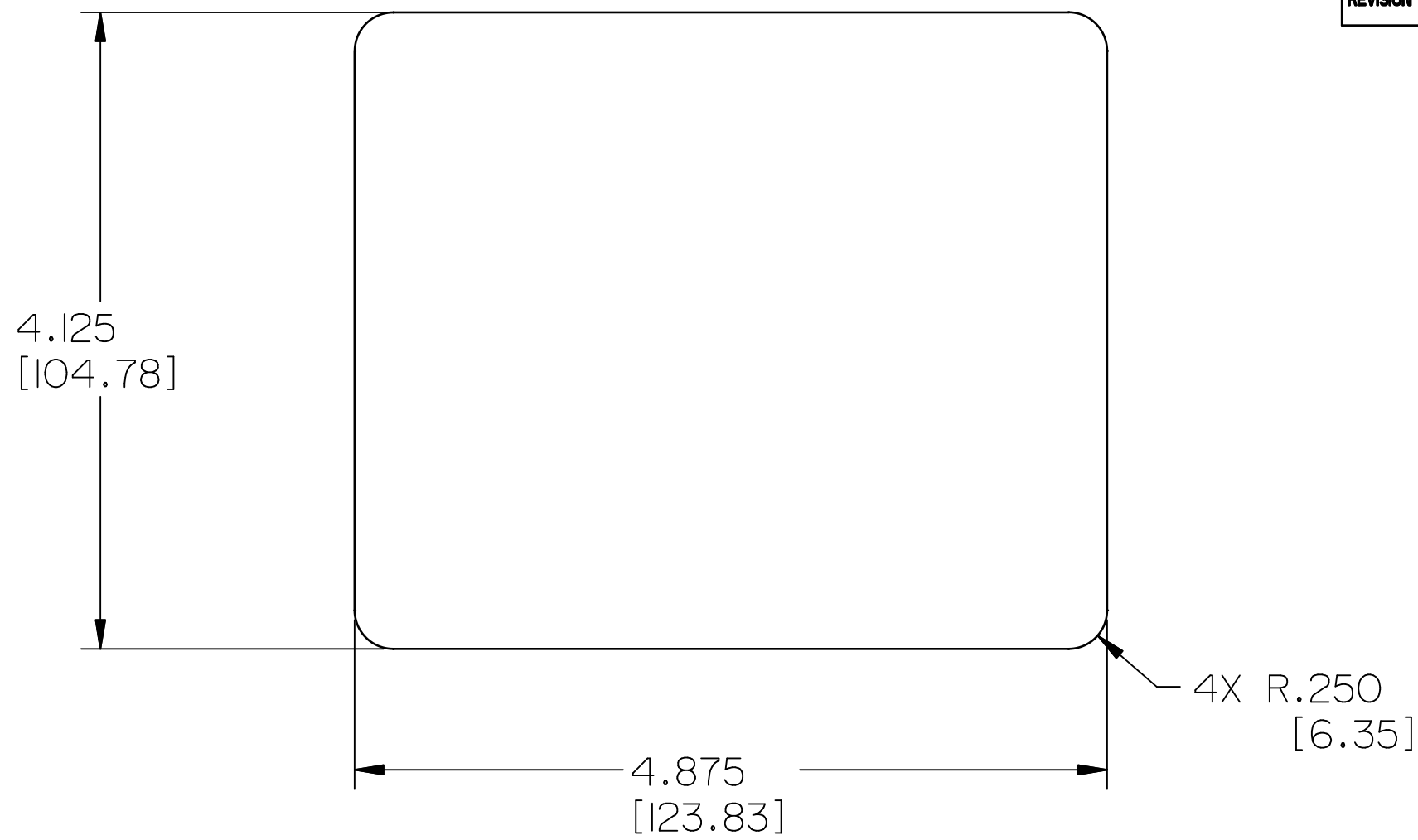

RECOMMENDED CUTOUT DETAIL

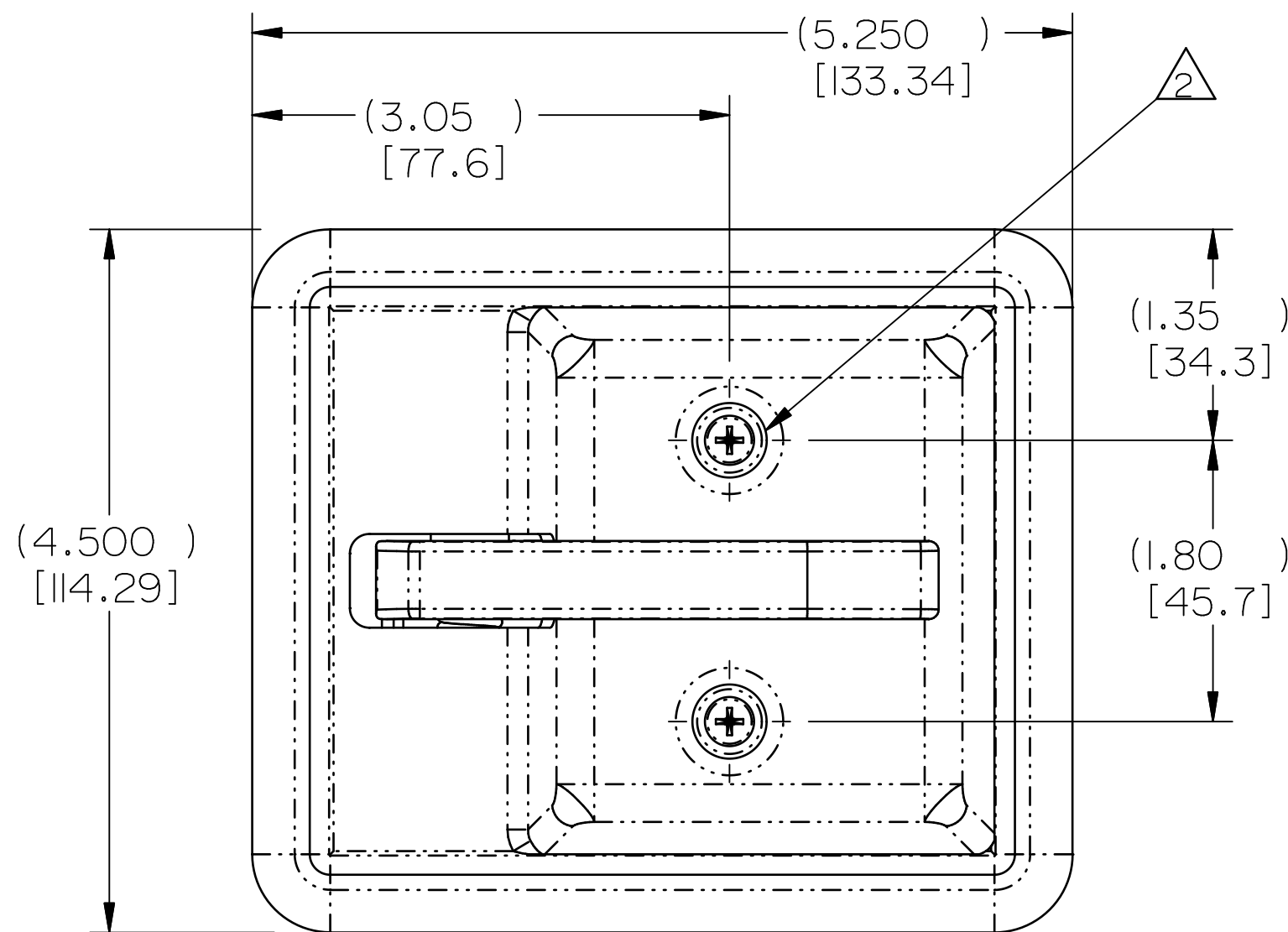

030-0425 RELEASE LEVER, INSIDE BEZEL

NOTES:

- △ TRIMARK PART NUMBER AND DATE CODE.
- △ TWO 8-18X.625 [15.88] BEZEL SCREWS FURNISHED.

SPECIFICATION		DESCRIPTION		ITEM	PART NUMBER	DESCRIPTION	QUANTITY	
DRAWN BY	JRS 3/15/02	MATERIAL				<p>500 Bailey Avenue New Hampton, Iowa 50659 U.S.A. Tel: 641-394-3188 Fax: 641-394-2392</p>		
CHECKED BY	CRZ 3/15/02	HEAT TREAT					<p>This drawing and the information contained herein is the property of TriMark Corporation and shall not be used for any purpose without our written consent.</p>	
DESIGN ENG.		FINISH			SEE TABLE			PART NAME
MFG. ENG.		PROJECT		CUSTOMER	CUSTOMER PART NUMBER			RELEASE LEVER/INS BEZEL
QUALITY ENG.		TOLERANCES		SIZE	PART WEIGHT	SURFACE AREA	PRODUCT CODE	
UNLESS OTHERWISE SPECIFIED		INCH		C			C10 (030-0425)	
		METRIC		REPORT ERRORS TO ENGINEERING DEPARTMENT		DO NOT SCALE DRAWING		
				SCALE	REVISION	PART NUMBER		
				FULL	0	PR12168-XX		