

UM 39

Instructions and Proper Use

Foretravel Passive Keyless Entry System



500-1350 RKE System

40758-03 PKE Controller

41849-02 PKE Transmitter

36444-02 Lighted Grab Handle with Keypad

36159-01 PKE Antenna



Optional Accessories

38146-01/02 Motor Home Entrance Door Handle with Capacitive Sense

41390-01 Antenna Bracket (Passive Entry/Door Option)

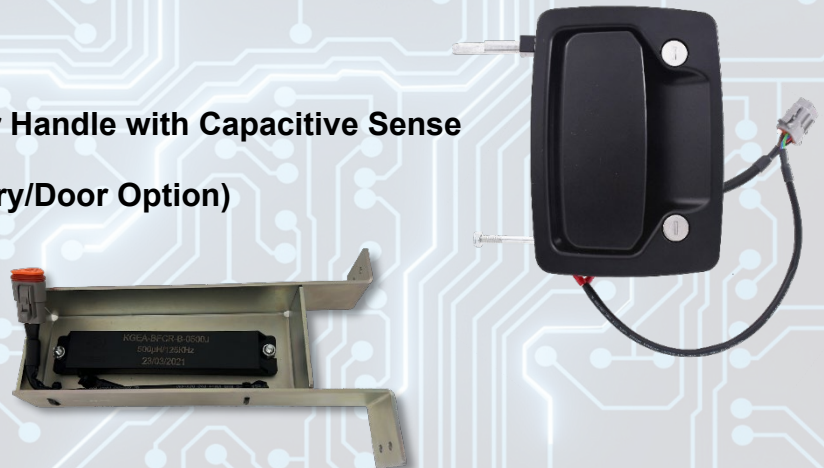

TriMark Corporation
500 Bailey Avenue
New Hampton, Iowa 50659
United States
www.trimarkcorp.com



TriMark

TriMark Corporation

TriMark Corporation

05/24-4

If you have a question regarding the Passive Keyless Entry System, please contact Spartan RV Customer Service at the following contacts before contacting TriMark Corporation:

Spartan/Shyft Recreational Vehicle Owner Support: rvcustomerservice@spartanvchassis.com
800.543.4277

Table of Contents

Table of Contents	2
Introduction	4
Acronyms	4
General Component Overview	4
e-FOB	4
PKE Controller	5
e-GRAB Lighted Grab Handle with Keypad.....	5
LF Antennas	5
Entrance Door Handle with Capacitive Sense (Optional).....	5
Chapter 1: Standard Operating Procedures	6
Passive Entry - Optional	6
Push to Start	6
Running	6
Shutdown.....	6
Lock All	6
Unlocking Entrance.....	6
Cargo Access	6
Alarm Functionality	6
Arming the Alarm	6
Feedback	7
Disarming the Alarm	7
Cancelling the Alarm.....	7
Tripping the Alarm	7
Auto Locking	7
Auto Lock / Unlock.....	7
Chapter 2: e-FOB Operation and Features	7
e-FOB Functionality	7
Pairing Fobs	8
e-FOB Guidelines	8
Chapter 3: Keypad / e-GRAB Operation and Features	9
Default Authority and Entry Codes	9
Keypads Can Store Multiple Entry Codes	9
Keypad Output Functions	10
Locking	10
Unlock the Entrance Door.....	10
Unlock All Doors	10
Enable Bay/Cargo Doors.....	10
Doorbell	10
Keypad Backlighting	10
Lockout Mode	11
Dome Light Activation.....	11
Keypad Buzzer Feedback.....	11
e-GRAB Handle Lighting	11
Teaching Keypad New Authority / Entry Codes	11
Programming the Authority Code	11
Programming the Authority Code	11
Programming Entry Codes	12

Chapter 4: Module Operation and Features	13
Module Connectors and Functions.....	13
Connector Locations	14
J1—Main Chassis Connector 24-Pin.....	15
J2—Parking Brake 10-Pin	15
J3—External Relay Drivers 8-Pin	15
J4—Relay Outputs 6-Pin.....	16
J5—Relay Outputs 4-Pin.....	16
J11—Push to Start PKE 12-Pin	16
J13—Entry Door PKE 14-Pin	17
DIP Switch Settings	17
Appendix A: Coin Cell Battery Warning	18
Appendix B: Wiring Diagrams	19
Appendix C: Installing Components	24
RF Antenna Guidelines.....	24
PKE Controller Mounting	24
PKE Controller: 40758-03.....	24
LF Antenna Guidelines	25
LF Antenna: 36159-01	25
e-GRAB Chrome Keypad: 36444-02.....	25
MH Entrance Door Handle with Capacitive Sensing	26
Appendix D: Error Codes	26
Appendix E: Troubleshooting	27
Appendix F: Warranty	28
Appendix G: Regulatory Information	28
Appendix H: RF Exposure Statement	29
Appendix I: Trademark Statement	29
Appendix J: Open-Source software notice	29

TriMark makes every attempt to assure that information contained in the User Manual is correct and accurate; however, changes in design, dimension and specifications may occur at any time and without notice. Please verify the revision level of this manual (see cover page) by referring to TriMark’s website under Product Code 500-1350.

Note: Product photos and illustrations may vary from your specific part numbers.

Introduction

This manual provides the necessary information for the proper installation and use of TriMark's **500-1350** system. The system comes with the following components:

- **e-FOB:** Keyless entry RF fob transmitter with passive entry and passive keyless start capability.
- **PKE Controller:** The input/output processor with low frequency (LF) and Radiofrequency (RF) transceiver capabilities.
- **Antennas:** LF interior antenna for **e-FOB** detection. LF door antenna for exterior detection.
- **e-GRAB Lighted Grab Handle with Keypad:** A five button chrome handle. It allows for locking and unlocking functions via a CAN network.
- **MH Entrance Handle:** Motor Home entrance handle with capacitive touch sense (optional).

This new generation of TriMark's **wireless product** not only maintains its previous advantages for controlling door and accessory control, but it also adds to the user experience by leaving the fob in your pocket or purse without having to press buttons. We've incorporated remote keyless entry, passive entry, passive start, and immobilization into a single package.

The fobs have typical lock/unlock buttons that can be used up to 50 meters depending on architecture and location. For security reasons, RF signals are encrypted using randomly generated numbers. This is what allows the system to start by pressing a button. The system uses the LF/RF messaging to ensure an authorized fob is within range inside the vehicle, or if so optioned that an authorized fob is close to the entrance door for true passive entry.

Acronyms

RKE: Remote Keyless Entry. The ability to lock/unlock the door by a button press on the fob.

PKE: Passive Keyless Entry. Fobs button presses are not required for entry. Simply put your hand in the handle and the system will search for the fob and unlock if the fob is authorized.

PKS: Ability to press the start button to start/stop the vehicle without pressing buttons on the fob.

Fob: The remote that allows PKE/RKE/PKS to work properly.

RF/LF: Radio Frequency. The frequency band that the module and fob communicate on. RF is 433 MHz, LF is 125 kHz.

CAN: Controller Area Network: This is a computer BUS system that is a highly accurate low data rate system that has been adapted by most vehicles throughout the world.

RV-C: This is the protocol/message structure used by the CAN network. This sets priorities, authentications, and configurations of the messages.

OEM: Original Equipment Manufacturer.

General Component Overview

e-FOB

- Stylish 4-button fob, FCC/IC/CE/UKCA compliant.
- RF transceiver that can reach 50 meters through open air.
- Controls main door lock and unlock, plus cargo enable/disable.
- Controls Panic alarm and lighting.

41849-02



PKE Controller

- Enables distributed functionality, such as multiple door control and ignition immobilization via vehicle multiplex communication plus passive entry
- CAN network functionality with error handling
- Fault displaying LEDs
- LF transceiver (FCC/IC compliant)
- RF transceiver (FCC/IC compliant)
- Selectable visual/audible controls

40758-03



e-GRAB Lighted Grab Handle with Keypad

- Entry assist handle incorporates TriMark's e-GRAB keypad into a stylish combo for RV coaches, motor homes and travel trailer
- Lighted rod and backlit keypad for greater visibility
- Button presses with tactile, visual, and audio feedback
- Communicates with the TriMark PKE Controller via CAN network
- Error/fault feedback via beeps and lighting
- Water and dust are resilient for outdoor environments

36444-02



LF Antennas

- Fob detecting internal antenna (inside dash) for push to start, exterior (in entrance door) for passive entry functions
- Potted construction ensures environmental protection and durability performance—can be used in exterior or interior locations

36159-01



Entrance Door Handle with Capacitive Sense (Optional)

- Enables passive entry while leaving e-FOB in your pocket or purse
- Integrated capacitive sensor automatically detects a hand and triggers a fob search and unlocks
- Can be unlocked with e-FOB unlock button or keypad with security code
- Deadbolt with traditional mechanical key for added security
- Power locking or unlocking does not affect the deadbolt, it unlocks or locks the paddle so that it moves or doesn't move
- If your motorhome has the standard handle, passive entry is disable

38146-01/02



Chapter 1: Standard Operating Procedures

Passive Entry - Optional

Inserting your hand behind the paddle of the main entrance door handle automatically initiates an exterior fob search via an antenna inside of the door. If the fob is in range (3.5 to 4 feet of the bottom of the door), it responds with a single LED blink. If the fob is authorized the handle unlocks.

Push to Start

Pressing the engine start button causes one of the non-TriMark controllers to activate the PKE Controller's Authorization Request input (J11P2 active) to begin the process of detecting a fob in range. The PKE Controller initiates a fob search via the antenna behind the dash. If the fob is in range (5 feet from the antenna) it responds with a single LED blink. If the fob is authorized, the PKE Controller activates its Authorization Response output (J11P4) to another non-TriMark controller that starts the engine.

Running

Once running, the fob is not required to keep the vehicle running. **Note:** You can drive away without your fob in the vehicle. You will not be able to start the vehicle again without the fob.

Shutdown

With your vehicle in park, a short press of the start/stop button turns off the vehicle.

Lock All

Press and hold the 1 button on the keypad (button 1) or press the lock button on the fob. This will lock the main door and disable cargo access.

Unlocking Entrance

Type in the five-digit entry code followed by the 1 button on the keypad or press the unlock button on the fob. This will unlock the main door and enable cargo access.

Cargo Access

When the vehicle is locked, cargo access is disabled. Pressing a button on one of the cargo doors will illuminate red to identify the vehicle is in the locked status. When the vehicle is unlocked, cargo access is enabled. Pressing a button on one of the cargo doors will illuminate green and cause the actuator for that door to power release.

Note: Programming new codes into your keypad can be found in Chapter 3: [Keypad Operation and Features \(36444-02\)](#) under Teaching Keypad New Authority / Entry Codes.

Alarm Functionality

Arming the Alarm

Performing a "lock all" with the keypad or the fob lock button attempts to **set** the alarm.

The word "attempt" is used above because several conditions can block the alarm from being armed:

- Parking brake not set (in gear). (J1P3 is NOT Grounded)
- Any security inputs are in the active state. (J1P13 grounded = active)
- Any door ajar inputs are in the active state. (J13P9 or J1P23 grounded = active)

Feedback

- If you activate the alarm from the keypad, the system sends a single pulse to the headlights
- If you activate the alarm from the fob, the system sends a single pulse to the headlights and horn/siren
- If you fail to activate the alarm the siren chirps 3 times

Disarming the Alarm

The alarm system will immediately be disarmed if one of the following things occurs:

- You start the engine
- Any door is unlocked by the fob, keypad, or a CAN message to unlock
- The Parking Brake is released

Cancelling the Alarm

Any of these conditions will cancel an active alarm:

- The vehicle is put into gear
- The engine is started
- An unlock command of any door main entry or cargo
- The alarm timer expires (60 seconds)

Tripping the Alarm

After setting the alarm, if the security input (J1P13) or the main door ajar input (J1P23), or the cargo door ajar (J13P9), are tripped (pins are grounded), the alarm activates. When active, the siren sounds and the headlights flash for one minute.

Auto Locking

Parking Brake		Description
Engaged	Active	The parking brake is active, and the vehicle cannot move. The vehicle is considered "not in use".
Released	Float	The vehicle can move if no other brakes are applied. The vehicle is considered "in use". This is usually caused by putting the vehicle into gear.

Auto Lock / Unlock

The parking brake is monitored for the auto locking feature:

- Whenever the vehicle parking brake is released, a timer is started. Seven seconds later a lock entrance door sequence is done.
- Whenever the vehicle parking brake is engaged, the entrance door is unlocked.

Chapter 2: e-FOB Operation and Features

e-FOB Functionality

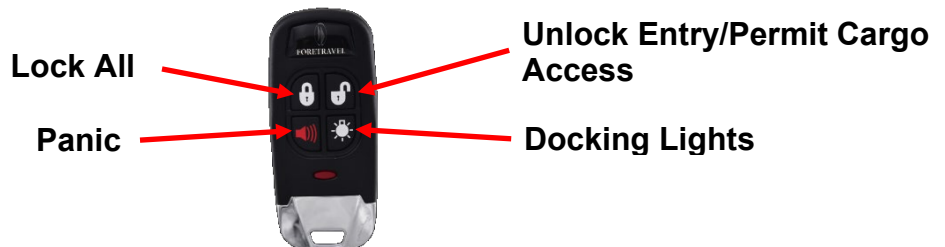

Button	Function
Lock All	Locks all doors and denies bay door access
Unlock Entry	Unlocks entry door with first press, enables bay door access with a second press, also activates dome light output for 60 seconds
Panic	Pressing button for 2 seconds activates Siren and Headlights outputs
Dock Lights	Toggles dock lights on/off if the parking brake is engaged. These will be turned off if the parking brake is released or a 10-minute timer has expired.

Pressing a button on the fob should cause the LED to flash once per second.

The fob is powered by a standard CR2032 3V battery.

Note: Typical use is 2 years without replacing the batteries. Battery life be subject to variation from OEM as the time the fobs were manufactured is not the day the coach was sold. Wireless phone chargers can also have a significant impact on battery life. Fobs sometimes cannot achieve deep sleep mode if near a wireless charger (2-4 feet depending on the charger). The 125 kHz noise generated by these chargers can also prevent the system from detecting a fob.

Pairing Fobs

You will need to have access to the module connectors or an OEM switch to pair fobs. To understand pin names and functions please reference Chapter 4: [Module Operation and Features \(40758-03\)](#). There may be a push button switch attached to J13P2 that connects this pin to +12V, if it is not supplied, short J13P2 (learn pin) to J11P1 (12Volt pin) when the steps below say “push button”.

Note: Programming new fobs will unlearn any programmed fobs previously stored. You may learn up to 20 fobs. Make sure you have all the fobs that you wish to program before starting this process.

1. Press the push button 3 times within 5 seconds (more than 3 is acceptable)
 - a. The PKE Controller locks, then unlocks the entry door as an audible indication that Fob Learn Mode is running
 - b. Two LEDs (red and green) located near the DIP switches inside the PKE Controller remain on flashing in tandem, while the controller is in learn mode
2. Press and release a button (any button) on each fob. Only 1 button per fob is necessary.
3. The PKE Controller locks then unlocks the entry door as an audible indication as each fob is added.
4. Wait 10 seconds after the last desired fob is added.
5. Entry door unlocks and the red and green LEDs stop flashing when you exit Fob Learn Mode.

e-FOB Guidelines

The e-FOB is designed to use commonly available CR2032 batteries. Estimated normal use should have an expected life of 2 years for the fob battery. Variances across commercial battery manufacturers and operating environment conditions may result in deviations from the expected battery life. The following guidelines should be followed to optimize fob battery life and system performance.

The e-FOBS are designed to operate in a low power or “sleep” mode. The fob electronics “wake up” upon detection of a button press or LF signal from the PKE Controller. The fob returns to “sleep” mode once the event that woke it up is completed.

When a fob is in proximity, 2-3 inches, from other vehicle control units, cell phones **or inductive cell phone charger pads, electrical signals from these devices can prevent the fob from returning to “sleep” mode and can reduce battery life.** Additionally, when near these other electrical devices, their emitted electrical signals can saturate the fob’s internal receiving antennas and prevent the fob from receiving proper LF signals.

It is recommended for optimal fob performance and battery life that a distance of at least 5-6 inches minimum be maintained between fobs and other such mentioned electronic devices. Due to the chemical process inherent in batteries, the performance of the e-FOB may be degraded at extreme temperatures. Operating temperature ranges vary across batteries from different manufacturers. For commercially available CR2032 batteries the typical operating temperatures ranges from -0C to +60C.

At cold temperatures, the battery’s chemical process is slowed down and can result in reduced fob range performance or an inoperative fob. When the battery is returned to warmer temperatures, normal performance will return. Extreme cold temperatures, below -20C, can cause a battery to freeze and fail due to expansion of internal plastic components. Simply replacing the battery allows the fob to function normally.

At extreme hot temperatures, the battery’s chemical process is accelerated. This may result in a reduced life expectancy of the battery. Normal fob range performance can be expected at higher temperatures if manufacturer limits are not exceeded.

Chapter 3: Keypad / e-GRAB Operation and Features

The keypad can store one authority code and four entry codes.
ALL TRIMARK KEYPADS USE 5-DIGIT CODES, NO more, NO less.

36444-02



- The authority code is used to create entry codes.
- The entry codes are used to unlock the vehicle.

This allows for the owner to have one code and make separate codes for someone else.

Default Authority and Entry Codes

	Digit 1	Digit 2	Digit 3	Digit 4	Digit 5
Authority	4	4	4	4	4
Entry	1	2	3	4	4

It is strongly recommended that you change all default codes to codes that you choose. Default codes are commonly known.

Note: If a code has been changed and you don’t know what it is, please go to the [Teaching Keypad New Authority / Entry Codes](#) section.

Keypads Can Store Multiple Entry Codes

- Entry codes can be stored as one Entry code per numbered button on the keypad. Doorbell keypads have 4 numbered buttons, so it can store 4 Entry codes
- These Entry codes do not allow different functions they only allow for multiple users

Doorbell Keypad	Numbered Button	Entry Code Position
4 Possible Entry Codes	1	1
	2	2
	3	3
	4	4
	DB	N/A

The DOOR BELL button is ignored when entering user codes and cannot be configured to be used to enter different codes.

Keypad Output Functions

- Outputs are accomplished after the ENTRY CODE is entered AND a selection is made
- When the ENTRY CODE is entered into the keypad properly the keypad will emit a two-beep tone
- After the two-beep tone there is a 5 second window to select a button option for an OUTPUT
- If no selection is made during the 5 second window the keypad returns to normal mode
- OUTPUTS ARE IN THE CHART BELOW

Example/default codes are shown, your codes should be different. The important item to note is the output that is expected with the 6th button press.

Entry Code	Button Option	= Output
1,2,3,4,4	1	Entry Unlock
1,2,3,4,4	2	Unlock Entry & Enable Cargo
1,2,3,4,4	3	Enable Cargo
1,2,3,4,4	4	NA
1,2,3,4,4	DB	N/A

Locking

No Code is REQUIRED to Lock

- Simply pressing the 1 button for 2 seconds causes the system to perform a Lock All command
- Keypads do not have separate commands for lock entry or lock cargo, they can only Lock All

Unlock the Entrance Door

Enter a valid 5-digit Entry Code (double beep from keypad) followed by button 1.

Unlock All Doors

Enter a valid 5-digit Entry Code (double beep from keypad) followed by button 2. Unlocks the entry door and enables Cargo access.

Enable Bay/Cargo Doors

Enter a valid 5-digit Entry Code (double beep from keypad) followed by button 3.

Doorbell

Pressing this button at any time without a code will cause J3P4 to toggle to ground momentarily which is wired to a doorbell if your motorhome is equipped with one.

Keypad Backlighting

Keypad buttons are lit when pressed and turn off 30 seconds after the last button is pressed.

Lockout Mode

If no Correct ENTRY CODE is entered in 20 button presses the keypad is disabled for 60 seconds. During this 60 second Lockout, the keypad will not beep or respond when buttons are pressed. This feature helps prevent random button attacks.

Dome Light Activation

Any time you press a button on the keypad, the dome light is activated for 30 seconds. When multiple buttons are pressed, the dome light will stay on for 30 seconds from the last button pressed. Pressing either Entry door or Cargo Door Unlock buttons on fobs also cause the dome light to activate for 30 seconds.

Keypad Buzzer Feedback

- In normal code entry mode, the keypad will emit 1 short 200mS beep per button press every time
- When the ENTRY CODE is properly entered the keypad will emit two short beeps
- During code *reprogramming* mode the keypad will emit two short beeps per button press
 - This will be covered in depth in the below section “Programming the Authority Code”
- On normal power up and keypad reset the keypad will emit a longer 1 second beep
- Three, longer 1-second beeps indicate brownout
 - Brownout means that the keypad is seeing less than 9 volts to its power input

e-GRAB Handle Lighting

- The E-Grab handle rod lighting is an LED, in the upper chrome portion of the handle
- It is powered by a separate source and is wired by the OEM specifically for your coach

Teaching Keypad New Authority / Entry Codes

All codes are exactly 5 digits. You may reuse numbers. Changing the Authority Code erases all Entry Codes. It is highly recommended that you change your Authority Code from the default authority code.

Programming the Authority Code

Note: There is a video of how to do this (it will not play on Apple tablets).

<https://www.trimarkcorp.com/en/media/Videos/eask/All%20Keypads/index.html>

The keypad is plugged into the coach’s wiring harness with a four-pin connector. You need to unscrew the keypad housing and pull it away from the coach to expose this connector. The yellow wire that is tucked into the sheathing is the wire that initiates Authority Code programming mode.

(The OEM may have extended this wire to a switch that grounds the yellow wire, this is dependent on your individual coach wiring. If the switch is installed, press it, wait for the keypad to beep & proceed to step 2)

Programming the Authority Code

1. With the keypad still plugged in, short the yellow wire to the black wire (GND) momentarily. This causes the keypad to beep for three seconds.
2. Enter the desired 5-digit Authority code, the keypad will beep twice per button press.
3. Enter the 5-digit Authority Code again. The keypad will beep twice per button press.
 - a. If the Authority code is entered twice correctly the keypad will beep 4 times.
 - b. If the Authority code is entered incorrectly or mistakes are made the keypad

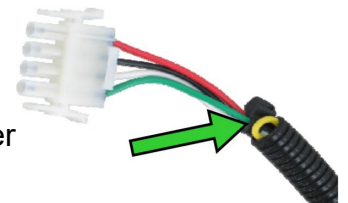

Does a long beep to indicate a failure to change the code.

4. After programming the system immediately exits Authority Code learn mode.
5. If you are looking for simple, and only need 1 access code, **you can be done at this point and the Authority code and Entry code are the same 5-digit code.** This is not recommended, but you only need to remember 1 code. You can test by entering your 5-digit code followed by the desired output button. (1), for example will unlock the entry door. **For greater security, we recommend you use an authority and one or more entry codes.**

Note: We recommend changing the Entry Code when an RV is acquired. The system automatically clears all Entry Codes and stores an Entry Code the same as your Authority Code in location button 1 any time the Authority Code is changed.

Programming Entry Codes

All codes are exactly 5 digits. You may reuse numbers. Have a number chosen.

1. Press and hold button 3, for 5 seconds. The keypad beeps again and begins flashing when it is held long enough.
2. Enter the 5-digit Authority Code.
3. If you enter the correct Authority code, you will hear a constant beep – continue to step 4.
 - a. If you enter the incorrect Authority code, you will hear a 1 second beep. Please double check the authority code.
4. Choose a location to store a code by pressing a location button once.
Button 1 = Location 1 Button 2 = Location 2
Button 3 = Location 3 Button 4 = Location 4
(Constant beep will end when a location selected)
5. Enter the desired 5-digit Entry Code. The keypad will beep twice per button press.
6. Enter the desired 5-digit Entry Code again. The keypad will beep twice per button press.
 - a. If the Entry Code is entered twice correctly the keypad will beep 4 times.
 - b. If the Entry code is entered incorrectly or mistakes are made the keypad does a **long beep to indicate a failure to program an entry code.**
7. Test your Entry Code by entering the 5-digit code followed by button 1 and the entry door unlock will unlock.

Note: You may store up to 4 codes in the system. You may write over a location by simply programming an entry code over that location.

This page can be printed and Owner- maintainer of Authority Code can record it here.

	Digit 1	Digit 2	Digit 3	Digit 4	Digit 5
Authority					
Entry 1					
Entry 2					
Entry 3					
Entry 4					

Chapter 4: Module Operation and Features

Module Connectors and Functions

If you look at the TriMark PKE Controller with the label pointed up, the numbering system is bottom right to top left (opposite of how you read). (See diagram below)

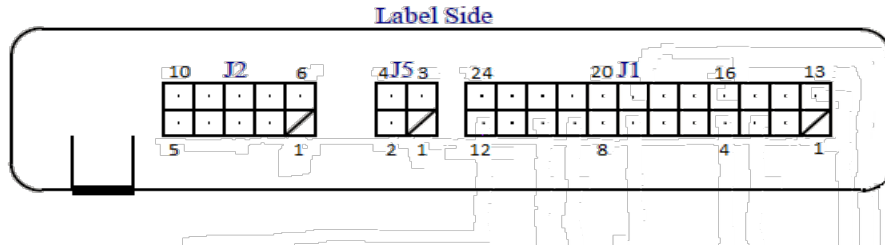

For all inputs:

- (-) indicates that the input normally floats (no predetermined voltage to input) unless a ground signal is placed to activate the pin.
- (+) indicates that the input normally floats (no predetermined voltage to input) unless a 12V signal is placed to activate the pin.
- (+/-) indicates that the input normally floats (no predetermined voltage to input), and the voltage is the opposite of J2P7 to activate (selectable).

For all outputs:

- (-) indicates upon activation a 500mA maximum ground will be activated.
- (Relay 20A) a momentary pulse to (vehicle power +12V) to lock/unlock doors, etc. The normal state of these pins is ground.
- (Relay 20A) Bank D has multiple pins to allow higher currents through these connectors. The four pins to allow this higher current are J1P5, J1P6, J1P17, and J1P18 described on the next page.

Note: Most fuses are based on wire gauges. Fuses should be gauged accordingly.

All signal wires must use twisted pair wires per industry standards:

- Follow CAN/RV-C protocol (see acronyms)
- LF antenna wires also need to be twisted pairs

Connector Locations

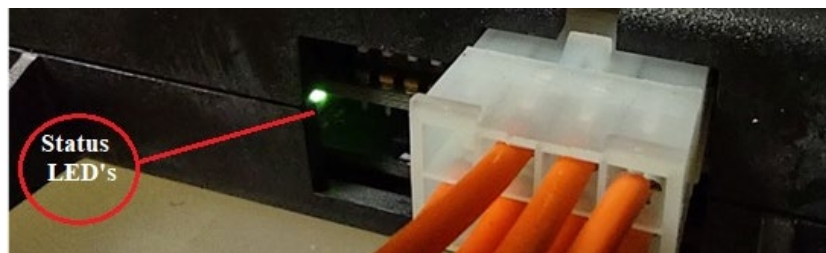
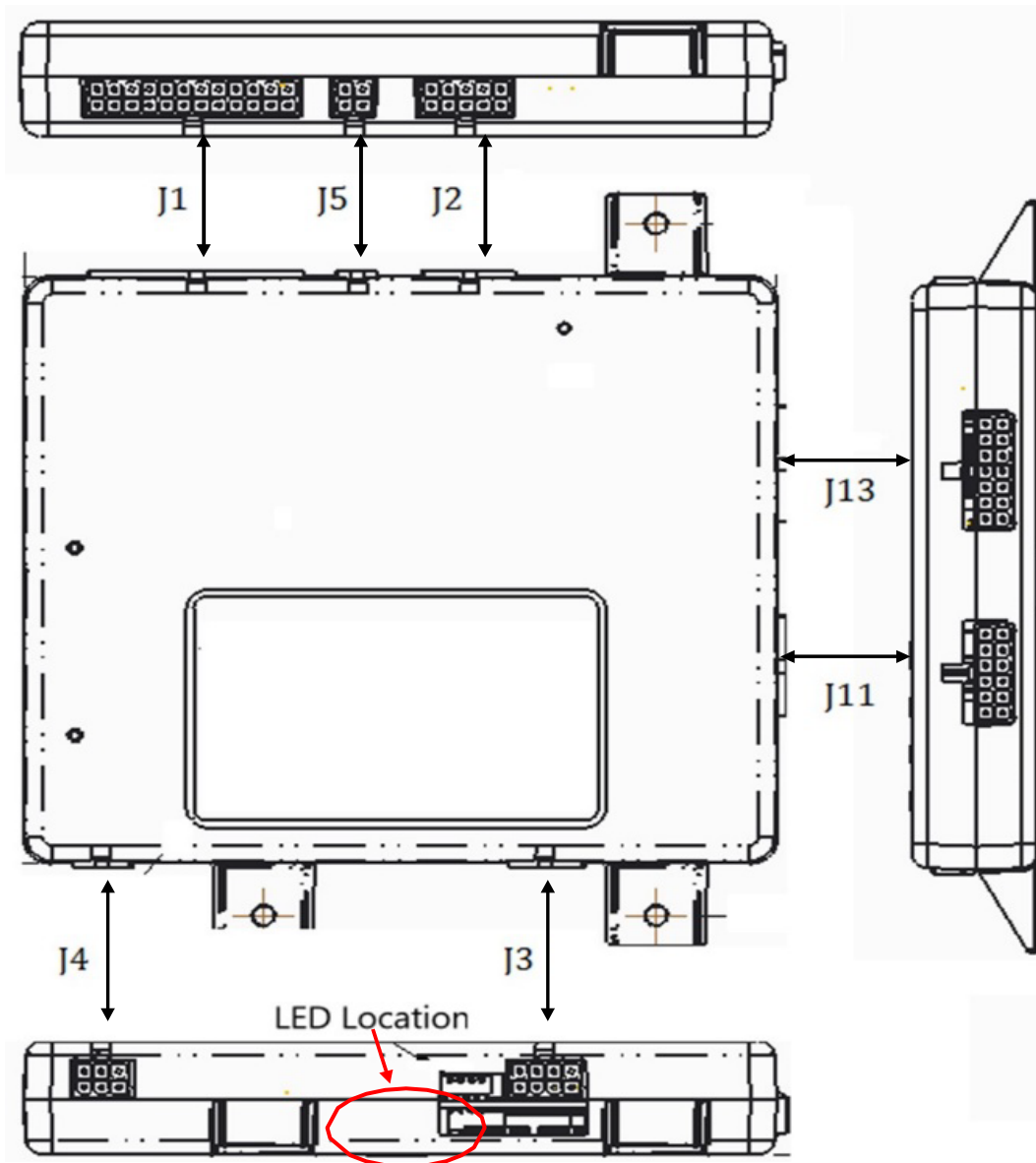

J1—Main Chassis Connector 24-Pin

Pin	Input/ Output	Function
J1P1	Input (-)	Cargo Access Enable input
J1P2	Input (-)	Cargo Access Disable input
J1P3	Input (-)	Parking Brake input (-)
J1P4 & J1P16	Input	Vehicle Ground
J1P5 & J1P17	Output (+/-)	(Unused Pin)
J1P6 & J1P18	Output (-/+)	(Unused Pin)
J1P7 & J1P19	Input	Vehicle Battery—Powers relays
J1P8	Output (+)	Entry Door Unlock: +Vin 20A max relay output
J1P9	Input (-)	Unlock Entry: Ground this input to unlock the entry door
J1P10	Input (-)	Cargo Access Request input
J1P11	Input (-)	Lock Entry & Deny Cargo Access
J1P12	Input (-)	Lock Entry: Ground this input to lock the entry door
J1P13	Input (-)	Security: Ground this input to indicate a break in and activate alarm
J1P14		(Unused Pin)
J1P15		(Unused Pin)
J1P20		(Unused Pin)
J1P21	Output (+)	Entry Door Lock: +Vin 20A max relay output
J1P22		(Unused Pin)
J1P23	Input (-)	Entry Door Ajar: Ground this input to indicate any of the entry doors are ajar
J1P24	Output (+)	Dome Light: +Vin 20A max relay output

J2—Parking Brake 10-Pin

Pin	Input/ Output	Function
J2P1	Input (+)	Vehicle Battery—Powers relays
J2P2		(Unused Pin)
J2P3		(Unused Pin)
J2P4		(Unused Pin)
J2P5		(Unused Pin)
J2P6	Input (-)	Vehicle Ground
J2P7		(Unused Pin)
J2P8		(Unused Pin)
J2P9		(Unused Pin)
J2P10		Vehicle Ground

J3—External Relay Drivers 8-Pin

Pin	Input/ Output	Function
J3P1	Output (+)	12V Regulated Power. 12V reference voltage for external relays.
J3P2	Output (-)	Horn for external relay (-500 mA)
J3P3	Output (-)	Headlight for external relay (-500 mA)

J3P4	Output (-)	Doorbell for external relay (-500 mA)
J3P5	Output (-)	Cargo Access Granted Output (Unlatches cargo release mechanism) (-500 mA)
J3P6	Output (-)	Door Ajar for external relay (-500 mA)
J3P7	Output (-)	Siren for external relay (-500 mA)
J3P8		(Unused Pin)

J4—Relay Outputs 6-Pin

Pin	Input/Output	Function
J4P1	Output (+)	Cargo Red Output (Activates LED on cargo door to indicate “access denied”)
J4P2	Output (+)	Cargo Green Output (Activates LED on cargo door to indicate “access granted”)
J4P3	Output (+)	(Unused Pin)
J4P4	Output (+)	(Unused Pin)
J4P5	Output (+)	(Unused Pin)
J4P6	Output (+)	(Unused Pin)

J5—Relay Outputs 4-Pin

Pin	Input/Output	Function
J5P1	Output (-)	Keypad Ground
J5P2		(Unused Pin)
J5P3	Output (+)	Keypad Power: 12V
J5P4		(Unused Pin)

J11—Push to Start PKE 12-Pin

Pin	Input/Output	Function
J11P1	Input (+)	Vehicle Battery: Powers all ICs and relays on J11 connector.
J11P2	Input (+)	AUTH_REQ: Input to request PKS system to locate fob near interior LF antenna.
J11P3	Output (-)	Low fob battery indicator (Activates to ground when fob is reporting low battery)
J11P4	Output (-)	AUTH_RESP: While AUTH_REQ is active, the PKE Controller activates this output if an authorized fob is in range.
J11P5		(Unused Pin)
J11P6		(Unused Pin)
J11P7	Output (+)	(Not Assigned) Relay 20 A
J11P8	Output (+)	(Not Assigned) Relay 20 A
J11P9	Signals	CAN Low: Connection to vehicle’s CAN bus.
J11P10	Signals	CAN High: Connection to vehicle’s CAN bus.
J11P11	Input (-)	Vehicle Ground
J11P12		(Unused Pin)

J13—Entry Door PKE 14-Pin

Pin	Input/Output	Function
J13P1		(Not Assigned)
J13P2	Input (+)	Fob Learn Mode Request: Using this input to program fobs.
J13P3		(Not Assigned)
J13P4		(Not Assigned)
J13P5		(Unused Pin)
J13P6		(Unused Pin)
J13P7		(Unused Pin)
J13P8		(Unused Pin)
J13P9		Input (-) Compartment Door Ajar
J13P10	Input	Vehicle Ground
J13P11		(Not Assigned)
J13P12		(Unused Pin)
J13P13	Input	Vehicle Ground
J13P14		(Unused Pin)

DIP Switch Settings

The DIP switches are there to enable/disable any visual/audio functions this controller provides. DIP switches are located next to the J3 connector.

DIP Switch	Function	On/Down	Off/Up
1	Unassigned		
2	Siren (J3P7)	Enable	Disable
3	Headlights (3P3)	Enable	Disable
4	Horn (J3P2)	Enable	Disable

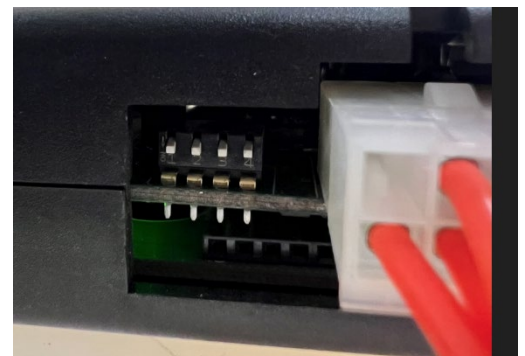

Appendix A: Coin Cell Battery Warning

WARNING: TriMark Keyless Entry Fobs contain a lithium button/coin cell battery. Keep coin cell batteries out of reach of children.

⚠ WARNING	
<ul style="list-style-type: none">• INGESTION HAZARD: This product contains a button cell or coin battery.• DEATH or serious injury can occur if ingested.• A swallowed button cell or coin battery can cause Internal Chemical Burns in as little as 2 hours.• KEEP new and used batteries OUT OF REACH of CHILDREN• Seek immediate medical attention if a battery is suspected to be swallowed or inserted inside any part of the body.	



1. Remove and immediately recycle or dispose of used batteries according to local regulations and keep away from children. Do NOT dispose of batteries in household trash or incinerate.
2. Even used batteries may cause severe injury or death.
3. Call the National Battery Ingestion Hotline (800-498-8666) or the Poison Help Line (800-222-1222) immediately for treatment information if you suspect a child has swallowed or is exposed to button cell or coin batteries.
4. The compatible battery type is CR2032.
5. The nominal battery voltage is 3V.
6. Non-rechargeable batteries such as the CR2032 are not to be recharged.
7. Do not force discharge, recharge, disassemble, heat above (manufacturer's specified temperature rating) or incinerate. Doing so may result in injury due to venting, leakage or explosion resulting in chemical burns.
8. Ensure the batteries are installed correctly according to polarity (+ and -).
9. Do not mix old and new batteries, different brands or types of batteries, such as alkaline, carbon-zinc, or rechargeable batteries.
10. Remove and immediately recycle or dispose of batteries from equipment not used for an extended period of time according to local regulations.
11. Always completely secure the battery compartment. If the battery compartment does not close securely, stop using the product, remove the batteries, and keep them away from children.

Appendix B: Wiring Diagrams

Push to Start

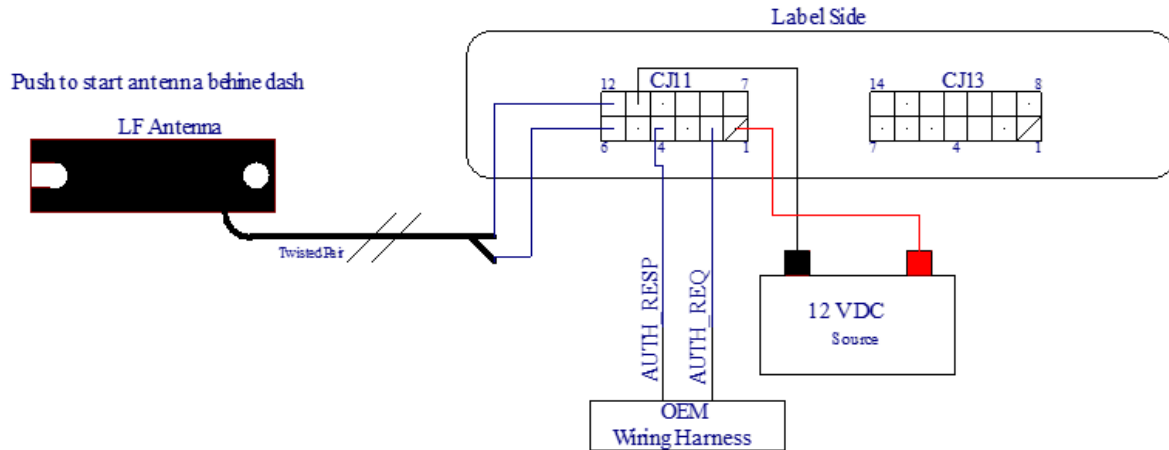

Entry Door (Standard)

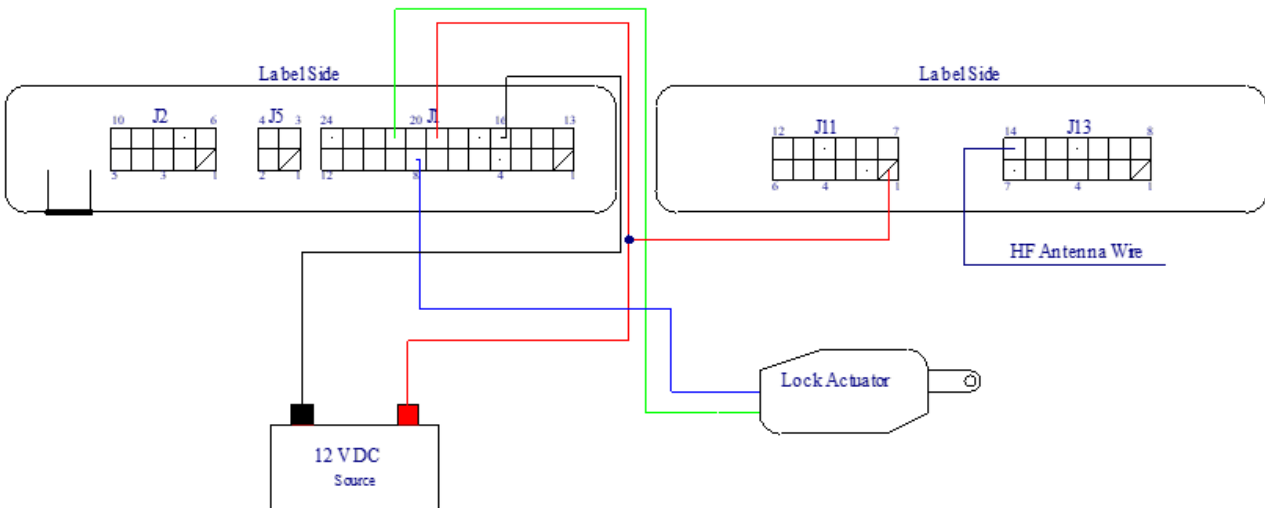

Passive Entry (Optional)

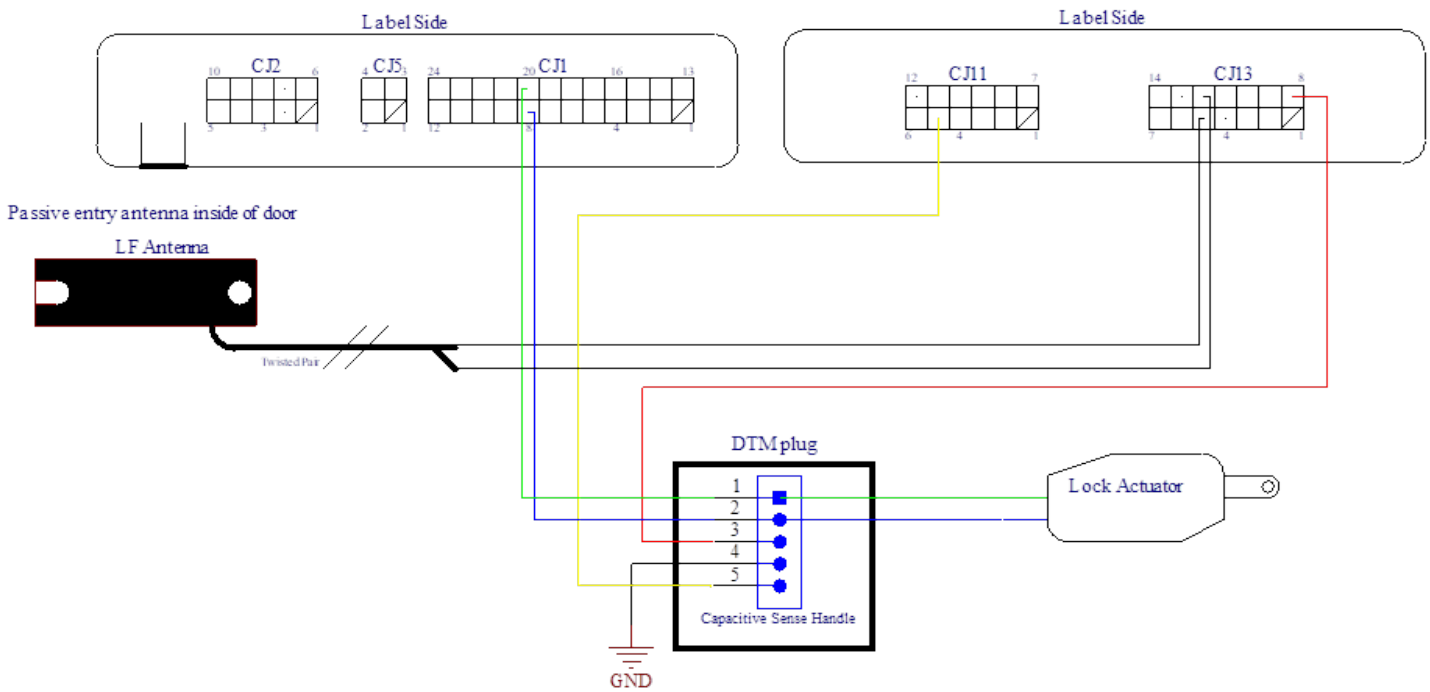

Keypad

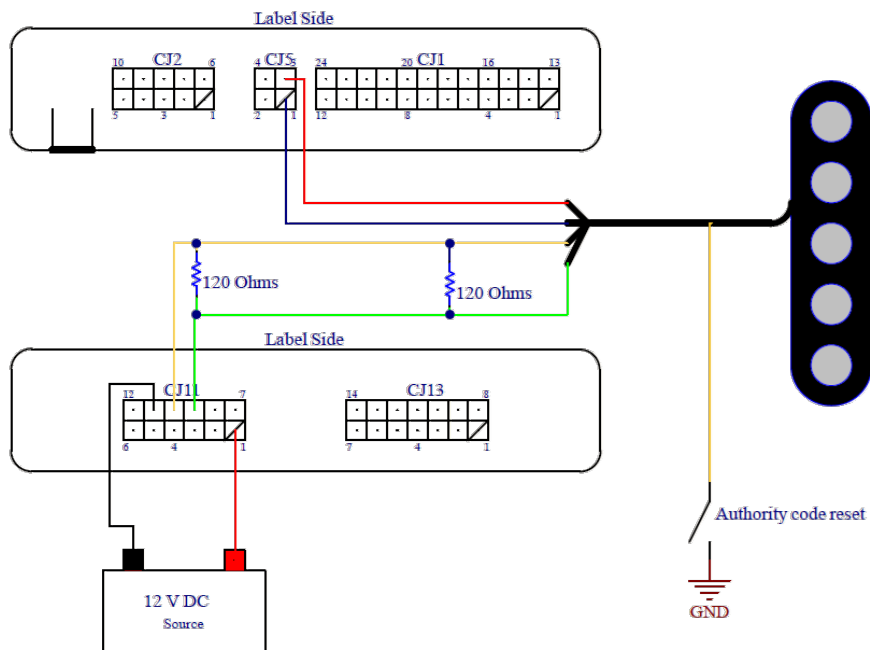

Cargo Enable

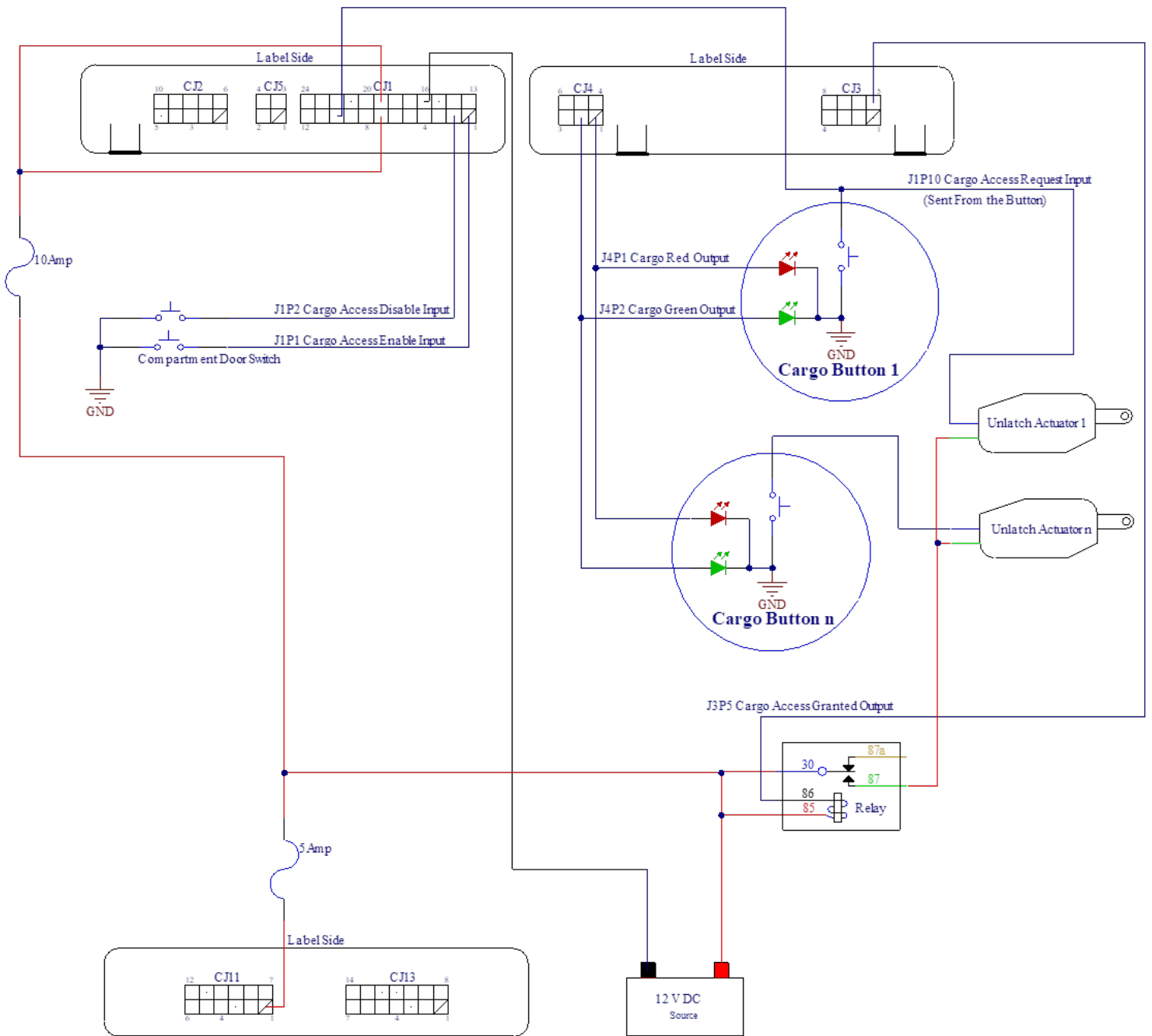

Accessories (Inputs)

SW1 = Cargo Door Ajar
 SW4 = Entry Door Ajar
 SW5 = Lock Entry Input
 SW6 = Lock Entry and Deny Cargo Door Access
 SW7 = Cargo Access Request Input
 SW8 = Entry Door Unlock
 SW9 = Park Brake Input
 SW10 = Programming Fobs
 SW12 = Security Input

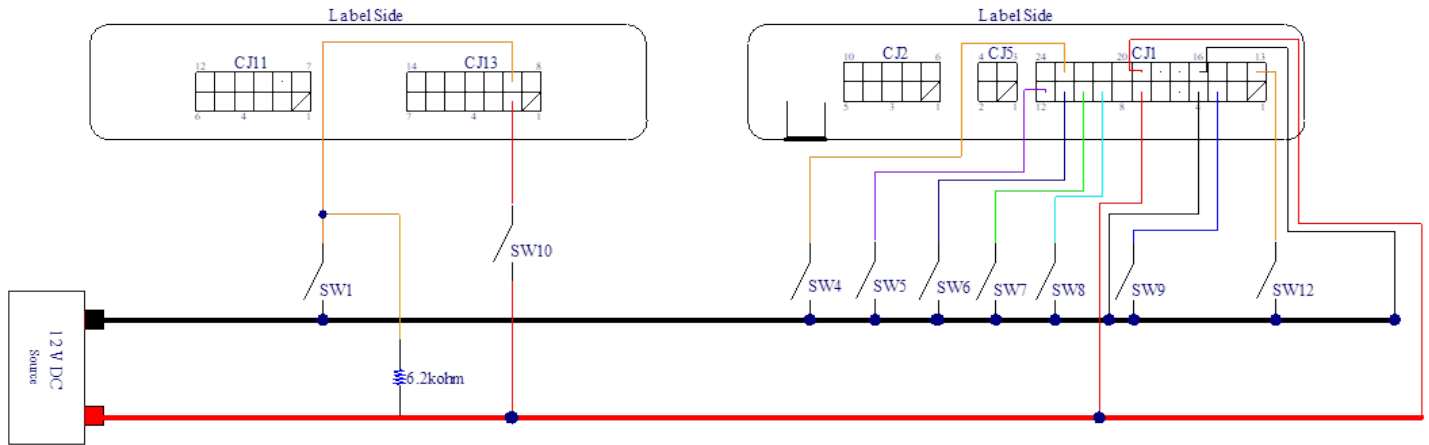

CAN Wiring and Requirements

- There must be at least two CAN devices on the CANH and CANL wires
- Terminating resistors are needed at each end of the CAN network (total of two)
- With everything unplugged, the harness must be 60 ohms between CANH and CANL
- Highly recommended that CANH and CANL wires are twisted together

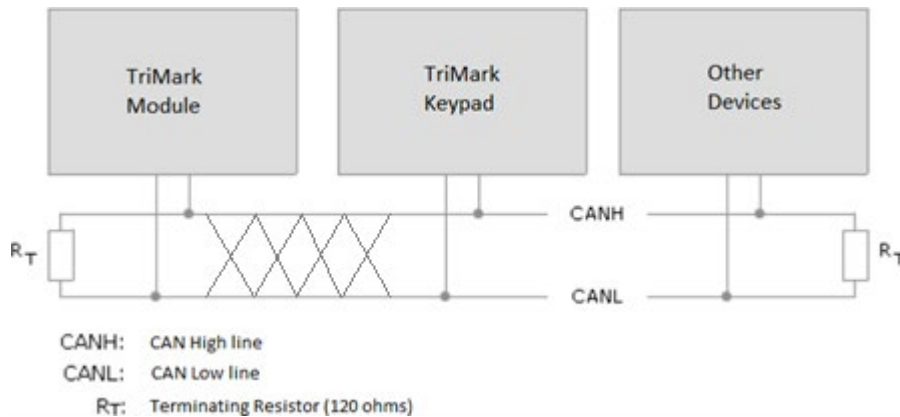

Accessories (Outputs)

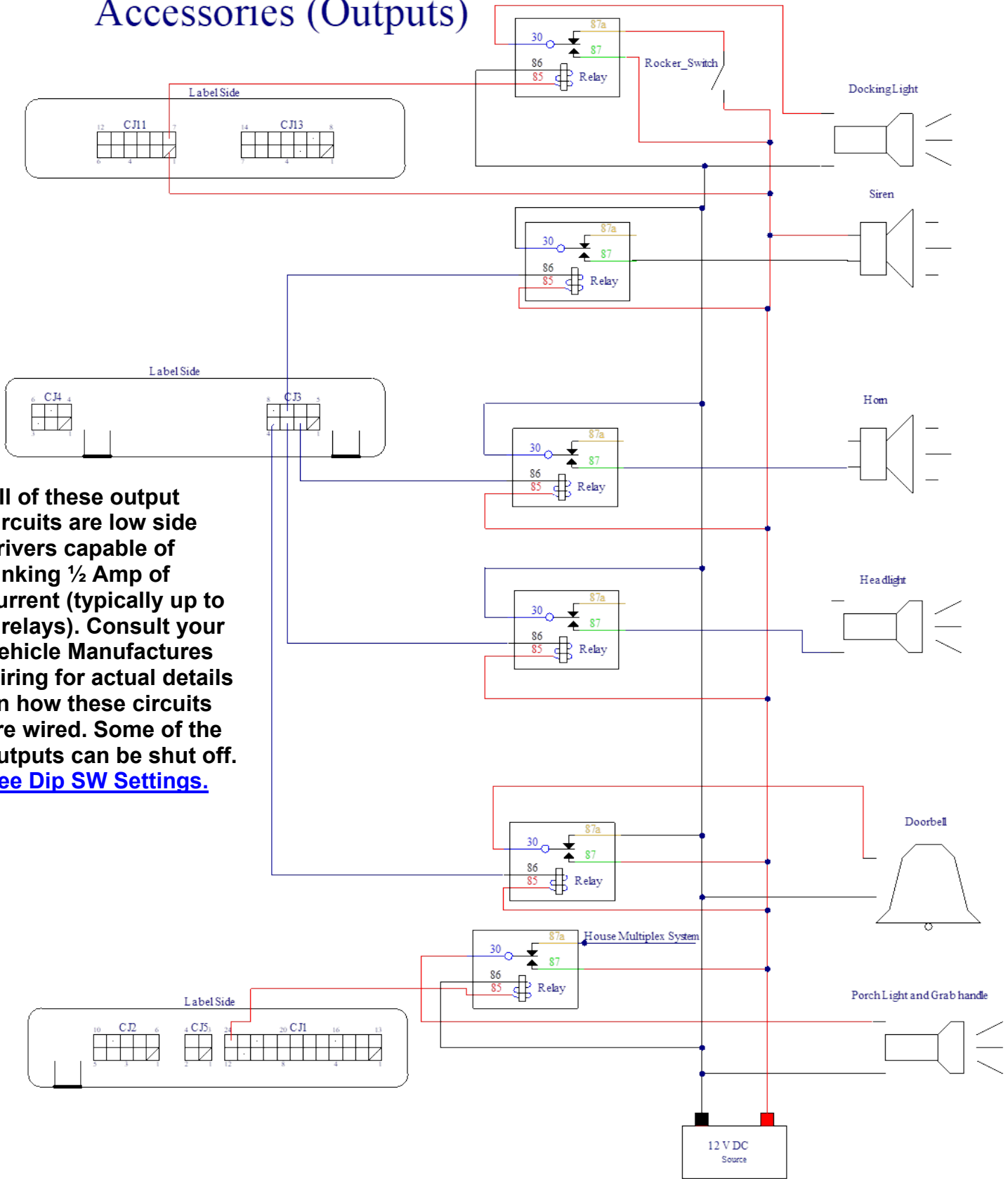

All of these output circuits are low side drivers capable of sinking 1/2 Amp of current (typically up to 2 relays). Consult your Vehicle Manufactures wiring for actual details on how these circuits are wired. Some of the outputs can be shut off. [See Dip SW Settings.](#)

Appendix C: Installing Components

This system uses low-voltage circuitry and wireless communication. To protect these components and to ensure the device operates as expected, these application notes must be followed.

RF Antenna Guidelines

Typical RF antenna implementation consists of a single wire from the control module. To ensure optimal reception the RF antenna wire should be designed to the following specifications:

Wire Length: 107.5cm +/- 1cm
Wire Type: 22AWG, Braided tinned

The tip of the antenna wire should also be covered with heat shrink tube or plastic dip to prevent the possibility of bare wire contacting vehicle chassis locations and grounding the antenna.

The RF antenna should be placed in an interior location that does not shield RF signals. You may need to try multiple locations to optimize reception. The antennae must be left fully extended and exposed.

Minimize shielding from metal enclosures or chassis body panels that could act as a ground plane.

Looping the antenna, wrapping the antenna around a metallic object, or grouping the antenna wire in with another wire harness may affect the operating range of the remote key fobs. Routing of the antenna wire near wires with large or rapid voltage fluctuations may also have a detrimental effect on fob communication. If the antenna wire must be routed with other wires due to vehicle design constraints, care should be taken in harness manufacturing to ensure the antenna wire is routed on the outside of the wire harness bundle and away from wires that have large or rapid voltage fluctuations.

PKE Controller Mounting

The module-PKE Controller contains several internal mechanical relays. If a relay is exposed to excessive G-force loads (greater than 30 G), it could toggle unexpectedly. It is important that the control module be mounted in a suitable location to prevent exposure to excessive G-force loads. Examples of poor mounting locations include on or inside doors, near chassis suspension features, or near internal-combustion engines.

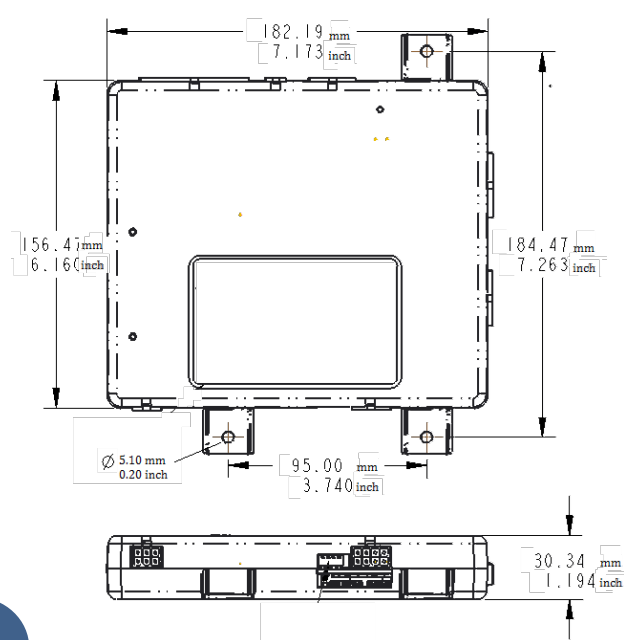

LF Antenna Guidelines

TriMark LF antennas are designed to be spaced off any metallic surfaces. Mounting the antenna to a metal surface without space will result in the antenna's transmitted signal to be absorbed and fob detection range will be reduced to a few inches. The suggested distance from the metal surface is 3/8" or farther. The LF antenna communication can also be disrupted by other electrical devices like inductive phone charging pads and high discharge LED screens.

LF Antenna: 36159-01

One LF is located behind the dashboard. This antenna searches for fobs for the Push to Start feature. A second optional antenna is located inside the door and is required for the Passive Entry feature. Both LF antennas are the 36159-01 part number.

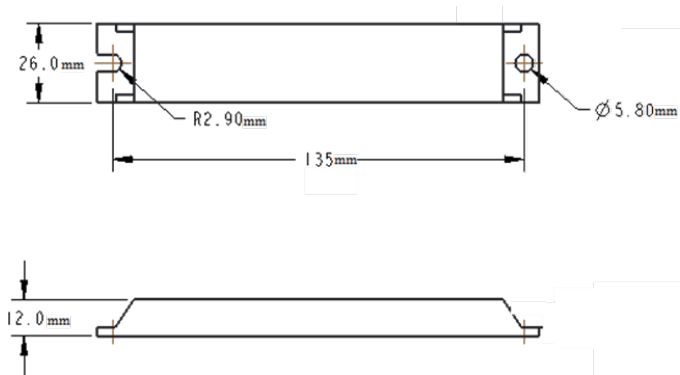

41390-01 LF Antenna assembly

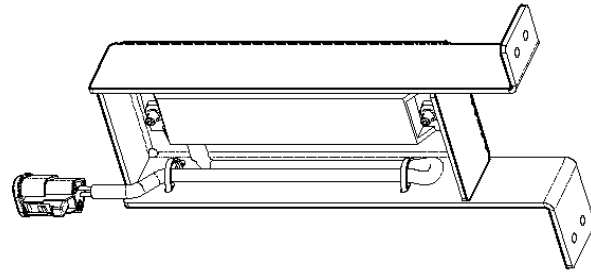

e-GRAB Chrome Keypad: 36444-02

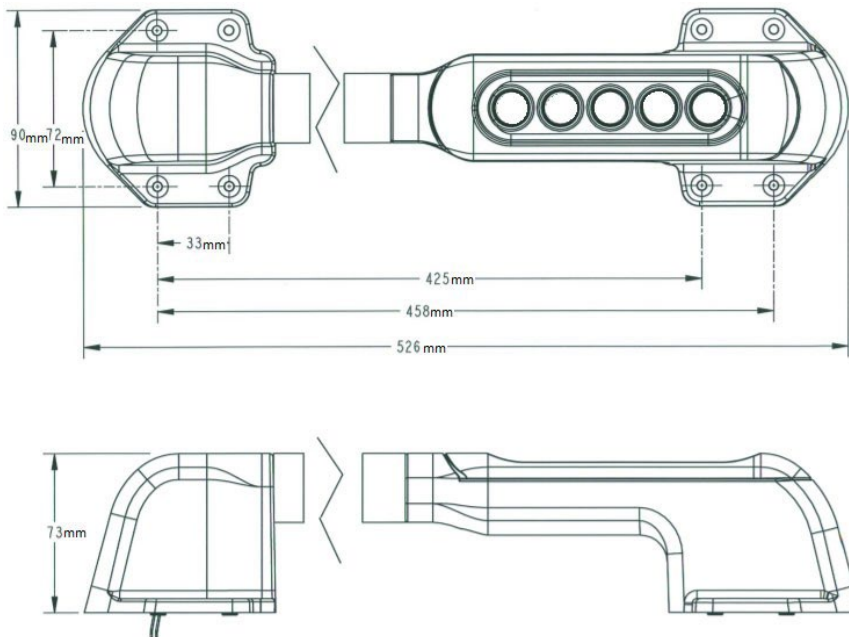

MH Entrance Door Handle with Capacitive Sensing

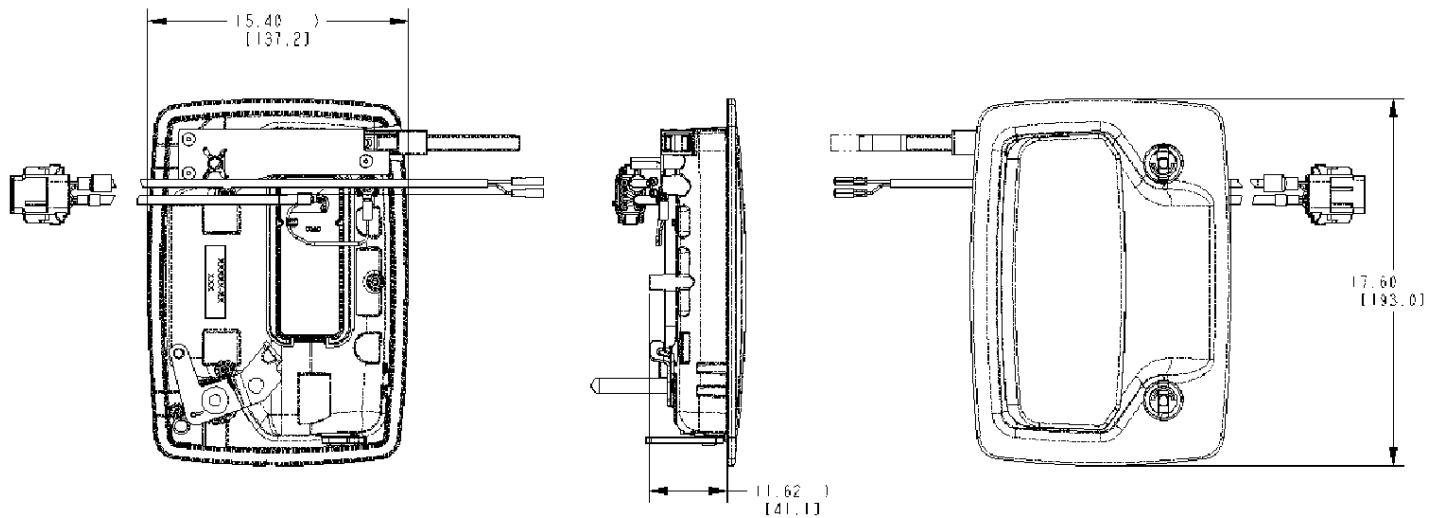

Appendix D: Error Codes

There are red and green LEDs located to the left of the controller programming port. This is visually shown in the Module Connectors and Functions under Connector Locations. The purpose of these LEDs is to indicate the mode the system is in.

Green LED	Red LED	Software Mode	Software Mode / Current State
On	Off	Customer Mode	Normal operation, full power state
Off	Off	NA	No Power
Fast blink	Off	Customer Mode	Initial power state at power on, waiting on super caps to fully charge
Off	Slow blink for X cycles then pause	Customer Mode	Run-time error detected, see table below
Fast blink	Fast blink	Fob Learn Mode	Waiting for fob input to add fobs to the Authorized Fobs List

Fault	Meaning	Run-Time Error Blinks
CAN Bus Communication Error	No CAN traffic for 10 seconds	1
CAN Voltage Out of Range, High	A CAN line is above 5 VDC	2
CAN Address Conflict	Two devices on bus claiming the same address	3
EEPROM Read/Write Error	Unable to read or write to EEPROM	4
LF Module Communication Error	Unable to communicate with LF PCB	5
I/O Expander Communication Error	Unable to communicate with I/O Expander PCB	6

Appendix E: Troubleshooting

Note: A complete power cycle requires that power is removed for 2 minutes!!!

Keypad is not functioning	
No audible beep when button is pressed	Check for power and good ground connection.
Keypad beeps one long and two shorter beeps	This is a CAN error and is usually due to wiring harness issues. Please refer to Appendix E: CAN Requirements for harness requirements. The keypad doesn't think it can communicate to the PKE Controller so it is nonfunctional until the CAN issue is resolved. This includes programming.
	Make sure module & keypad has power. There are two LEDs; one red and one green. They are located inside the module. One or the other should be blinking or on. Connector Locations section identified the location.
	Replace keypad.
I put the 5-digit code in, and it doesn't do a double beep	Reprogram entry code.
Will not lock or unlock	
Pressing Lock or Unlock will not operate a specific door by keypad or fob	Clean door contacts. Power is supplied to the actuator through spring loaded metal conductors. Make sure they are clean.
	Check actuator (replace if needed). These actuators are 12V bi-directional. You should be able to activate them with 12VDC one way to lock and the other to unlock.
	Check voltage at door contact, the controller sends a .5 second pulse one direction for lock, and the other for unlock. Most voltmeters average over .75 seconds so you may not see the 12VDC, but you should see your voltmeter show a voltage above 9 volts.
	Check harness for continuity.
Lock and unlock will not unlock any doors by keypad or fob	If you can hear the internal relays click, check power to either the J1 connector or the J2 connector. The power to the relays is separate from the power to the electronics. The J11 connector powers the electronics and the relay coils (the clicking sound). J1 and J2 connectors are on the same power source. Powering one, powers them both. For relays to give power one or both will need power given to it.
	Nothing is happening. Check the fuses. Check system LEDs. For locations of LED please go to section Connector Locations . Check power to the J11 connector .
Lock and unlock work with the keypad, but not with fobs	Change fob battery.
	Re-sync fob(s).
The fob works but it is intermittent or has bad range	
Sometimes the fob works and sometimes it doesn't	Arrange the RKE antenna as discussed in the RF Antenna Guidelines .
	Cycle power to the system off (2 minutes min), then on again.
One fob is not syncing	When you sync fobs, all fobs need to be sync'd at the same time. With any sync, it erases previously sync'd fobs.

The light & horn stopped providing lock or unlock confirmations	Check DIP switch settings to see if it's turned off.
	Check external relays triggered by PKE Controller.
	Check wiring continuity. See Accessories in wiring diagrams .

Appendix F: Warranty

TriMark warrants that the products manufactured and sold shall be in accordance with specifications and free from defects in materials and workmanship for a period up to 18 (eighteen) months following the date of delivery to TriMark's customer or 12 (twelve) months from the original O.E.M. sale (in-service) date. Where TriMark does not have design control regarding customer supplied products, materials or specifications, the warranty is limited to non-conforming products.

This warranty is expressly limited to persons who purchase TriMark's products for the purpose of resale or use in the ordinary course of the buyer's business. This warranty does not cover any product that if TriMark Corporation determines (in its sole discretion) that a product's failure or malfunction is due to one or more of the following conditions, such failure or malfunction is EXCLUDED from the warranty provided hereunder: (1) used in a manner that exceeds published engineering specifications; (2) has been abused, misused, disassembled/opened, altered/modified, or improperly installed; (3) is used in an application not previously approved by TriMark; (4) is used in a manner inconsistent with any instructions and good industry practices regarding its use; (5) wear or deterioration due to environmental conditions; (6) unusual mechanical, physical or electrical stress or (7) is destroyed/damaged by fire, lightning or an act of God. In addition to the above, TriMark will not warrant any electrical/electronic products with (8) burned or broken traces on the printed circuit board; (9) burned or damaged components; (10) dirt or water residue on the printed circuit board or inside the case; (11) motor failure due to thermal failure; (12) or dead batteries.

This warranty is exclusive, and TriMark makes no other warranty of any kind whatsoever, expressed, or implied, with respect to the products manufactured and sold by it, whether as to merchantability, fitness for a particular purpose or any other matter. Without prior written authorization from the Board of Directors, no agent, employee, or representative of TriMark has any authority to bind TriMark to any affirmation, representation or warranty concerning TriMark products or parts, except as stated herein.

If any product supplied by TriMark is found to be defective by TriMark in its sole discretion, TriMark reserves the right to replace, rework, repair, or give credit for defective product. Upon confirmation of the defective condition of the subject part either with return of subject part and/or proper documentation, TriMark will replace such defective product exclusive of any labor, shipping, transportation, or delivery cost associated with the replacement. TriMark will not be responsible for the cost of removal of a defective product. This remedy shall be the exclusive remedy available for any defects in the products manufactured and sold by TriMark or for damages resulting from any other cause whatsoever, including without limitation, TriMark's negligence. The purpose of this exclusive remedy shall be to provide the buyer with replacement of products or parts sold by TriMark found to be defective in materials or workmanship or negligently manufactured. This exclusive remedy shall not be deemed to have failed in its essential purpose so long as TriMark is willing and able to replace said defective products or parts in the prescribed manner.

WITHOUT LIMITING THE FOREGOING, TRIMARK SHALL NOT BE LIABLE FOR CONSEQUENTIAL OR INDIRECT DAMAGES, ECONOMIC LOSSES, LOSS OF USE, LOST PROFITS, DOWN TIME, OR DAMAGES DUE TO DELAY, WHETHER BY REASON OF BREACH OF WARRANTY, BREACH OF CONTRACT, NEGLIGENCE, STRICT LIABILITY OR OTHERWISE.

This product has been manufactured with methods to ensure high quality and to meet the high expectations of our customers. TriMark warrants this product to be free from workmanship defects and will remedy issues per TriMark's warranty policy.

Remote transmitter fobs, batteries, and other equipment subject to normal wear and deterioration may need to be replaced periodically by dealer and/or end user and are not covered by this warranty. TriMark will not be liable for indirect, special, incidental, or consequential damages.

Appendix G: Regulatory Information

This device complies with Part 15 of the FCC Rules. Operation is subject to the following two conditions:

(1) This device may not cause harmful interference, and (2) This device must accept any interference received, including interference that may cause undesired operation.

Le manuel d'utilisation des appareils radio exempts de licence doit contenir l'énoncé qui suit, ou l'équivalent, à un endroit bien en vue et/ou sur les appareils :

This equipment has been tested and found to comply with the limits for a Class A digital device, pursuant to part 15 of the FCC Rules. These limits are designed to provide reasonable protection against harmful interference when the equipment is operated in a commercial environment. This equipment generates, uses, and can radiate radio frequency energy and, if not installed and used in accordance with the instruction manual, may cause harmful interference to radio communications. Operation of this equipment in a residential area is likely to cause harmful interference in which case the user will be required to correct the interference at his own expense.

Changes or modifications (moving the LF antenna for example) not expressly approved by the manufacture could avoid the user's authority to operate the equipment.

This device complies with Industry Canada license-exempt RSS standard(s). Operation is subject to the following two conditions: (1) this device may not cause interference, and (2) this device must accept any interference, including interference that may cause undesired operation of the device.

Le présent appareil est conforme aux CNR d'Industrie Canada applicables aux appareils radio exempts de licence. L'exploitation est autorisée aux deux conditions suivantes : (1) l'appareil ne doit pas produire de brouillage, et (2) l'utilisateur de l'appareil doit accepter tout brouillage radioélectrique subi, même si le brouillage est susceptible d'en compromettre le fonctionnement.

Appendix H: RF Exposure Statement

The device shall be used in such a manner that the potential for human contact normal operation is minimized. This equipment complies with RSS-102 radiation exposure limits. This equipment should be installed and operated with a minimum distance of 20 cm between the radiator and your body. This device and its antenna(s) must not be co-located or operating in conjunction with any other antenna or transmitter.

Le dispositif doit être utilisé de manière à minimiser le potentiel de fonctionnement normal par contact humain. Cet équipement est conforme aux limites d'exposition au rayonnement RSS-102. Cet équipement doit être installé et utilisé avec une distance minimale de 20 cm entre le radiateur et votre corps. Cet appareil et son (ses) antenne (s) ne doivent pas être co-localisés ou utilisés conjointement avec une autre antenne ou un autre émetteur

Note: No part of this publication may be copied, modified, revised, reproduced, distributed, reused, transmitted to a third party, or translated in any language without the prior written permission of TriMark Corporation.

Appendix I: Trademark Statement

Trademarks, logos and service marks ("Trademarks") used on TriMark website(s), product literature, manuals, communications or other representations in the name of TriMark including, but not limited to "TriMark," "e-ASK," "e-FOB," "e-GRAB," "e-PAD," "TriGuard," "Access Series," "TIPS," and "KeyOne" are registered and unregistered trademarks of TriMark. Nothing in this communication should be construed as granting by implication, estoppel, or otherwise, any license or right to use any Trademark displayed and user agrees that it will not, without prior written consent, use and/or associate TriMark's Trademarks with any promotional, advertising, instructional, reference materials, in or on websites, products, labels, or packaging. USERS ARE ADVISED THAT TRIMARK WILL AGGRESSIVELY ENFORCE ITS INTELLECTUAL PROPERTY RIGHTS TO THE FULLEST EXTENT OF THE LAW.

Appendix J: Open-Source software notice

This product may contain embedded software from open-source communities. The open-source software (OOS), copyright, licensing terms and conditions are located at the following link:

<https://www.trimarkcorp.com/en/media/pdf/OpenSSL%20Acknowledgement%20Statement%20on%20Website.pdf>